

Installation Instructions / Warranty

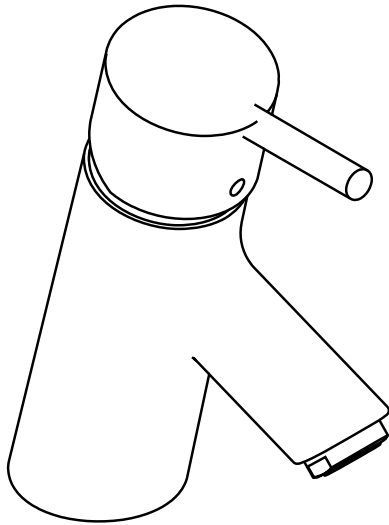

Talis S
32020XX1

hansgrohe

Talis S Lavatory Mixer

32020XX1

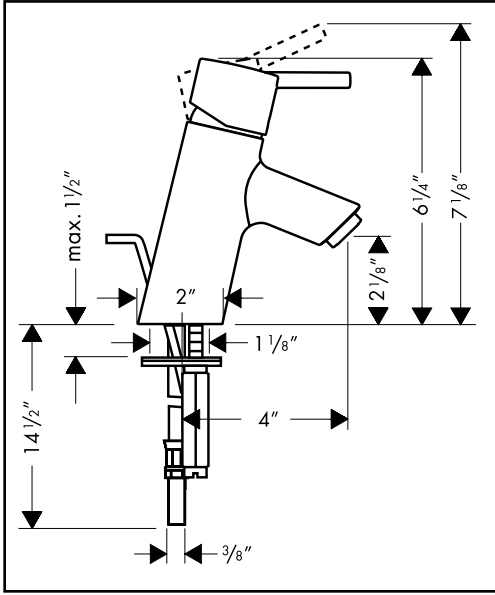

32020XX1

Technical Specification

Flow Rate	2.2 gpm
Max incoming water pressure	145 psi
Recommended incoming water pressure	14.5 - 72 psi
Max incoming hot water temperature	176°F*
Recommended incoming hot water temp.	120°F - 140°F*
Maximum mounting surface thickness	1 1/2"
Hole size	1 1/4"

*Prevent accidental scalding - know and follow all applicable local plumbing codes when setting the temperature on the water heater!

Installation Considerations

This faucet requires supply stops with 3/8" compression fittings (not included).

Please be sure that the faucet is in good condition, and that all parts are present before beginning installation.

Flush the supply lines thoroughly before installing the faucet. Damage to the cartridge caused by debris is not covered by the Hansgrohe USA Limited Lifetime Warranty.

The faucet includes a high temperature limit stop which should be re-set to protect children from accidental scalding.

Installer - please leave this manual for the homeowner as it contains important information on the faucet.

Installation

If the mounting surface is less than $3/16''$ thick, carefully trim the spacer ring so that it is even with the bottom of the faucet.

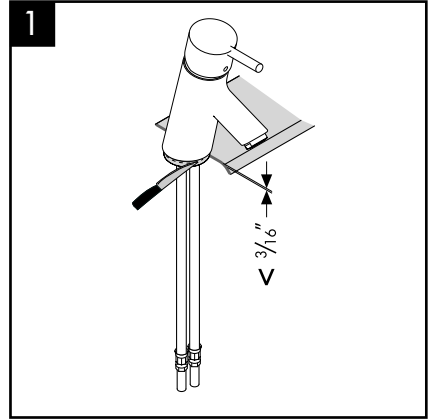

If the mounting surface is greater than $3/16''$, leave the spacer ring intact.

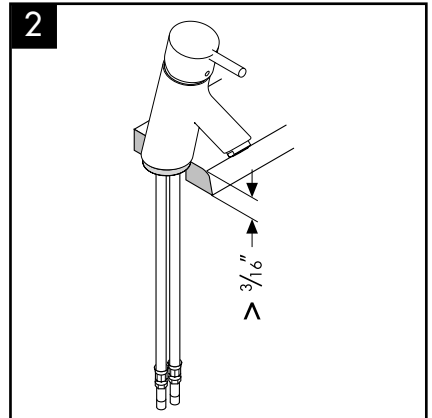

Place the mounting plate over the stud. Tighten the collar so that it is snug against the bottom of the mounting surface.

Install the supply hoses to the stops with the compression fittings, taking care not to twist the supply hoses.

Install the pop-up drain.

Re-set the high temperature limit stop.

Turn on the water and test all connections for leaks.

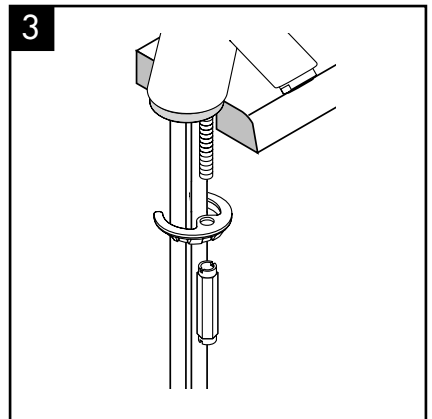

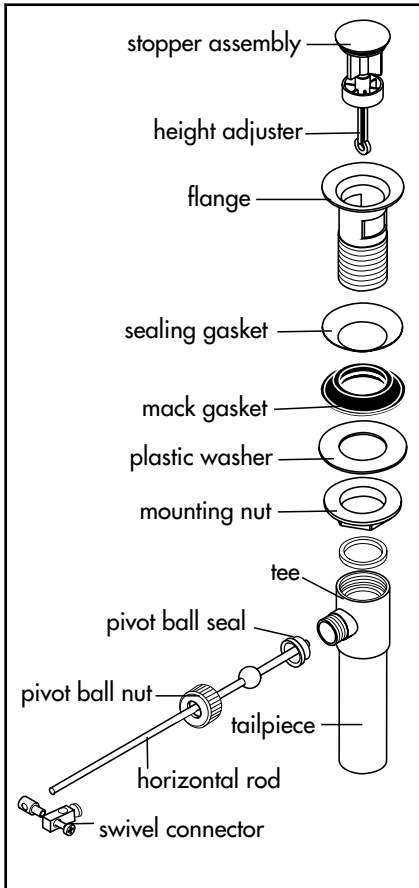

Install the Pop-up Drain:

Unscrew the flange from the tee. Place the tee and sealing gasket on top of the sink. From below, install the black mack gasket, plastic washer, and mounting nut to the flange.

Thread the tee to the flange from beneath the sink. The tee must be turned so that it faces the faucet. When satisfied with the orientation, tighten the mounting nut.

Sit the stopper assembly in the drain.

Install the horizontal rod so that the end goes through the loop in the bottom of the stopper height adjuster.

Install and hand tighten the pivot ball nut.

Attach the swivel connector to the end of the horizontal rod. Attach the swivel connector to the end of the vertical rod. Position the vertical rod as desired, and tighten it with a small, flat-bladed screwdriver.

Test the drain for function. If necessary, reposition the swivel connector.

User Instructions

Pivot the handle up to turn the water on, down to turn it off. Pivot the handle to the right for cooler water, to the left for warmer water.

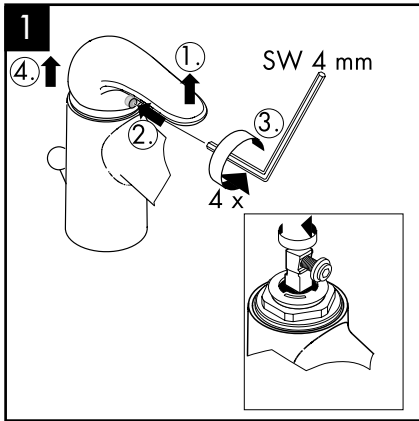

Reset the high temperature limit stop:

Turn the water off at the stops. Push the handle to the full up position (1). Loosen the handle screw 4 complete turns with a 4 mm allen wrench (2). Pull off the handle (3) and the nut cover.

Turn the stem so that the handle screw faces forward.

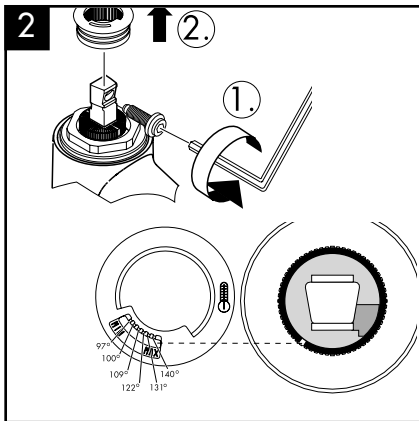

Remove the handle screw (1). Pull off the high temperature limit stop (2).

Reinstall the high temperature limit stop so that the pin on the cartridge goes through the hole for the desired high temperature.

The temperatures shown on the illustration assume an incoming cold water temperature of 50°F, and an incoming hot water temperature of 140°F.

Test the faucet. If the high temperature is still too hot, reposition the high temperature limit stop.

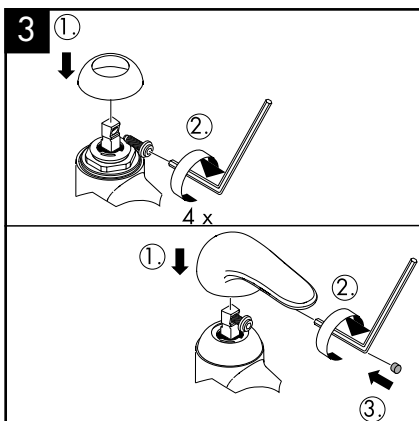

Replace the nut cover (1). Replace the handle screw and tighten it 4 complete turns.

Replace the handle (1). Finish tightening the handle screw (2). Install the screw cover (3)

Replacement Parts

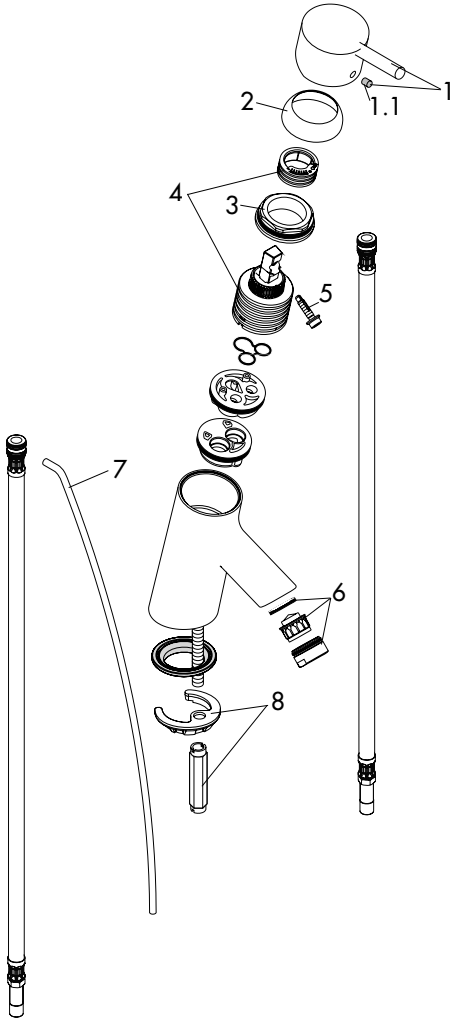

1	handle	32092000
1.1	screw cover	96338000
2	flange	96656000
3	nut	96690000
4	cartridge	92730000
5	handle screw	96059000
6	aerator	13085000
7	pop-up rod	96657000
8	mounting set	96016000

Cleaning Recommendation for Hansgrohe Products

Modern faucetry and shower products utilize a combination of materials to comply with the needs of the market with regard to design and functionality.

To avoid damage, it is necessary to use some caution when cleaning. Damage caused by improper treatment is not covered under the Hansgrohe warranty.

Cleaning Materials for Faucets and Showers

- To remove lime scale, use only products made specifically for that purpose. Always follow the manufacturer's instructions when using.
- Do not use cleaners that contain hydrochloric, formic, acetic, or phosphoric acids, as these will cause considerable damage to finishes and to plastic components.
- Never mix cleaning materials.
- Never use cleaners containing abrasives. Do not use abrasive cleaning cloths, pads, or sponges.

Cleaning Procedures

- Clean your faucets and shower products as and when required. Regular cleaning will prevent scale buildup and water spotting.
- Follow the label instructions. Do not allow any cleaner to remain on the product for longer than necessary.
- When using spray cleaners, spray first onto a sponge or cloth – do not spray directly onto the product.
- After cleaning, rinse thoroughly with clear water to remove any cleaner residue.

Important

- Soap and shampoo residue can also cause damage to the product. Rinse well with clean water after use.
- If the surface is already damaged, harsh cleaning materials will cause further damage.

Limited Lifetime Consumer Warranty

This product has been manufactured and tested to the highest quality standards by Hansgrohe, Inc. ("Hansgrohe"). This warranty is limited to Hansgrohe products which are purchased by a consumer in the United States after March 1, 1996, and installed in either the United States or Canada.

WHO IS COVERED BY THE WARRANTY

This warranty extends to the original consumer purchaser only.

WHAT IS COVERED BY THE WARRANTY

This warranty covers only your Hansgrohe manufactured product. Hansgrohe warrants this product against defects in material or workmanship as follows: Hansgrohe will repair at no charge for parts only or, at its option, replace any product or part of the product which proves defective because of improper workmanship and/or material, under normal installation, use, service and maintenance. If Hansgrohe is unable to provide a replacement and repair is not practical or cannot be timely made, Hansgrohe may elect to refund the purchase price in exchange for the return of the product.

LENGTH OF WARRANTY

Replacement or repaired parts of products will be covered for the term of this warranty as stated in the following two sentences. If you are a consumer who purchased the product for use primarily for personal, family, or household purposes, this warranty extends for as long as you own the product and the home in which the product is installed. If you purchased the product for use primarily for any other purpose, including, without limitation, a commercial purpose, this warranty extends only (i) for 1 year, with respect to Interaktiv and Retroaktiv products, and (ii) for 5 years, with respect to AXOR, ShowerPower and Pharo products.

THIS WARRANTY DOES NOT COVER, AND HANSGROHE WILL NOT PAY FOR:

- A. Conditions, malfunctions or damage not resulting from defects in material or workmanship.
- B. Conditions, malfunctions or damage resulting from (1) improper installation, improper maintenance, misuse, abuse, negligence, accident or alteration, or (2) the use of abrasive or caustic cleaning agents or "no rinse" cleaning products, or the use of the product in any manner contrary to the product instructions.
- C. Labor or other expenses for the disconnection or return of the product for warranty service, or for installation or reinstallation of the product.
- D. Accessories or related products not manufactured by Hansgrohe.

TO OBTAIN WARRANTY SERVICE

Contact your Hansgrohe retailer, or write to Technical Service at:

Hansgrohe Inc.
1492 Bluegrass Lakes Parkway
Alpharetta GA 30004

Or, call Hansgrohe toll-free at (800) 334-0455.

In requesting warranty service, you will need to provide

1. The sales receipt or other evidence of the date and place of purchase.
2. A description of the problem.
3. Delivery of the product or the defective part, postage prepaid and carefully packed and insured, to Hansgrohe Inc. 1492 Bluegrass Lakes Parkway, Alpharetta, Georgia 30004, Attention: Technical Service, if required by Hansgrohe.

When warranty service is completed, any repaired or replacement product or part will be returned to you postage prepaid.

EXCLUSIONS AND LIMITATIONS

REPAIR OR REPLACEMENT (OR, IN LIMITED CIRCUMSTANCES, REFUND OF THE PURCHASE PRICE) AS PROVIDED UNDER THIS WARRANTY IS THE EXCLUSIVE REMEDY OF THE PURCHASER. HANSGROHE NEITHER ASSUMES NOR AUTHORIZES ANY PERSON TO CREATE FOR IT ANY OBLIGATION OR LIABILITY IN CONNECTION WITH THIS PRODUCT.

HANSGROHE SHALL NOT BE LIABLE TO PURCHASER OR ANY PERSON FOR ANY INCIDENTAL, SPECIAL, OR CONSEQUENTIAL DAMAGES, ARISING OUT OF BREACH OF THIS WARRANTY OR ANY IMPLIED WARRANTY (INCLUDING MERCHANTABILITY).

Some States do not allow the exclusion or limitation of incidental or consequential damages, so the above limitation or exclusion may not apply to you.

This warranty gives you specific legal rights, and you may have other rights which vary from State to State.

You may be required by law to give us a reasonable opportunity to correct or cure any failure to comply before you can bring any action in court against us under the Magnuson-Moss Warranty Act.

PRODUCT INSTRUCTIONS AND QUESTIONS

Upon purchase or prior to installation, please carefully inspect your Hansgrohe product for any damage or visible defect. Prior to installing, always carefully study the enclosed instructions on the proper installation and the care and maintenance of the product. If you have questions at any time about the use, installation, or performance of your Hansgrohe product, or this warranty, please call or write to us at the toll-free number and address printed above.

hansgrohe

Hansgrohe, Inc. • 1490 Bluegrass Lakes Parkway • Alpharetta, GA 30004
Tel. 770 360-9880 • Fax 770 360 9887

www.hansgrohe-USA.com